

Wideband Receivers: Design Challenges, Tradeoffs and State-of-the-Art

Fujian Lin, Pui-In Mak, and Rui P. Martins

Abstract

A universal wideband receiver supporting multi-band multi-standard wireless communications offers the prospective for cost reduction and flexibility improvement of next-generation handheld devices. Unlike the traditional narrowband receivers that are tailored for specific standards and are assisted by dedicated SAW filters to restrict the input signals (frequency and power), SAW-less wideband receivers are fully exposed to the dynamic spectrum conditions, stimulating circuits and systems innovation to surmount the challenges while keeping up the integration level, power and area efficiencies. This article outlines the design challenges and fundamental tradeoffs of wideband receivers, and describes how they can be addressed by three circuit techniques: *noise cancelling*, *N-path filtering* and *N-path mixing* improving the noise figure, out-of-band linearity and harmonic-rejection capability, respectively. Case studies of silicon-proven solutions representing the state-of-the-art are included, illustrating the pros and cons of different implementation and combination of such three techniques. Architecturally those wideband receivers can be classified as: i) current-mode passive-mixer receiver; ii) voltage-mode passive-mixer receiver; iii) current-mode active-mixer receiver, and iv) current-mode parallel active/passive-mixer receiver. This article should be relevant to junior designers preparing to jump-start in this evolving field, and experience designers intended to collectively compare the existing solutions before further development.

Digital Object Identifier 10.1109/MCAS.2014.2385571

Date of publication: 17 February 2015

Fujian Lin, Pui-In Mak, and Rui P. Martins are with the State-Key Laboratory of Analog and Mixed-Signal VLSI and FST-ECE, University of Macau, Macao, China; Rui P. Martins is on leave from Instituto Superior Técnico, University of Lisbon, Portugal. E-mail: pimak@umac.mo.

I. Introduction

In order to create fully autonomous and seamless wireless connectivity in the years to come, innovative wireless circuits and systems solutions are especially essential to support a variety of radio technologies such as Wi-Fi, Global Positioning System (GPS), Bluetooth, 3G/4G cellular and imminent short-range mmWave links in one battery-powered handheld device. In fact, the aims of maximum hardware reuse and battery life while keeping up the communication speed and user experience incessantly challenge the front-to-back-end development of emerging wireless products.

Narrowband radios can be easily resorted from external SAW filters to reject the out-of-band blockers during the signal reception [1], while a high-gain low-noise amplifier (LNA) can be safely adopted at the front to optimize the sensitivity at low power. Yet, the spectrum diversity of existing and upcoming wireless standards pressures the cost and universality of emerging multi-service wireless terminals. In recent years, the research focus has been trended towards SAW-less wideband receivers that can be software-defined for different bands and specifications [2, 3]. Wideband radio frequency (RF) techniques have emerged as the major direction to realize the next generation wireless multi-standard products in expensive nm-length CMOS technologies.

Although the rapid downscaling of CMOS has benefitted the speed-to-power efficiency of RF circuits, the reduction of supply voltage and device's intrinsic gain has aggravated the difficulty of upholding the dynamic range [4]. Specifically, without any RF pre-filtering, broadband noise and high-power blockers can directly go into the receiver deteriorating its sensitivity. As a result, SAW-less wideband receivers having concurrently low noise figure (NF), high blocker tolerability and minimum external components are of great importance, though very challenging. It is expected that large-scale research and development activities of wireless chips will be continued in the coming years to address them, motivating the need of an overview article that can consolidate the key concepts and state-of-the-art techniques in an easy-to-understand-and-compare style, being very suitable for junior designers to jump into the topic, or experience designers to have a collective study of existing works.

This article overviews the design challenges and fundamental tradeoffs of an illustrative wideband receiver in Section II, before describing three corresponding techniques: noise cancelling, N-path filtering and N-path mixing to address them in Section III. The performance comparison and classification of state-of-the-art wideband receivers are discussed in Section IV, and the conclusions are drawn in Section V.

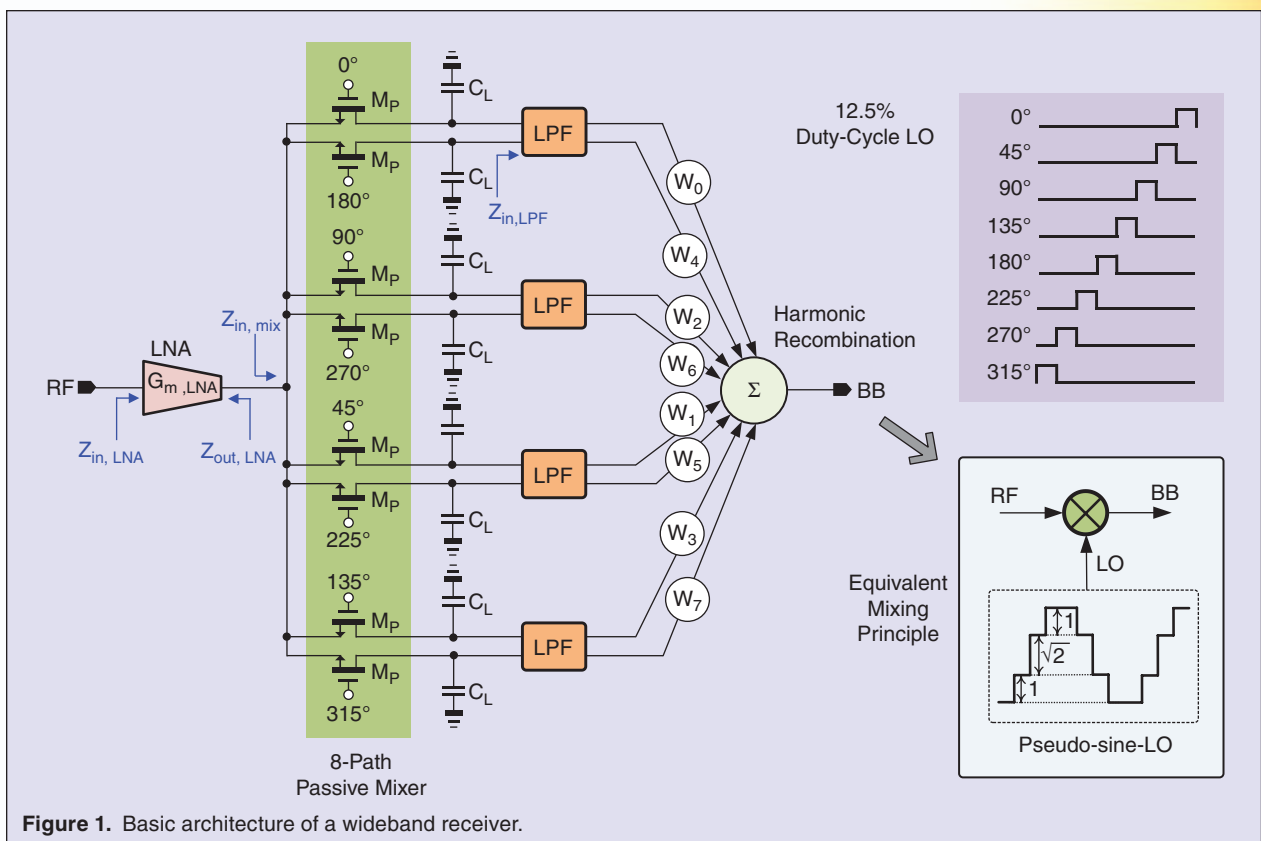

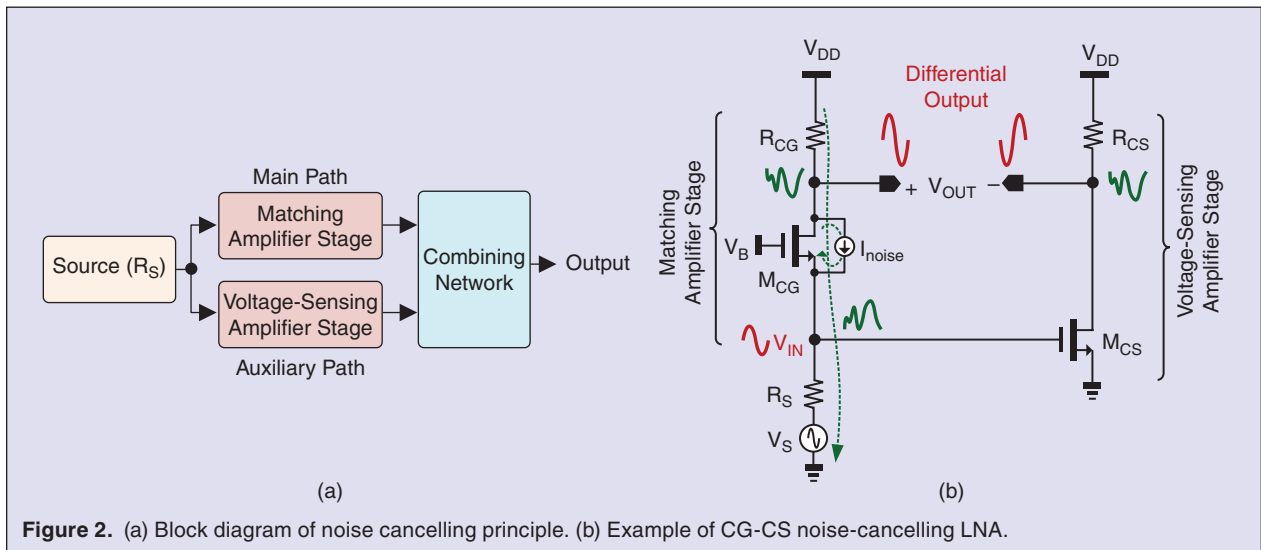

Figure 2. (a) Block diagram of noise cancelling principle. (b) Example of CG-CS noise-cancelling LNA.

Table 1. Performance summary of current-mode passive-mixer wideband receivers.

	Z. Ru et al. [2] ISSCC'09	C. Andrews et al. [3] ISSCC'10	D. Murphy et al. [7] ISSCC'12
Architecture	Current mode, passive mixer		
RF input style	Differential	Single-ended	Single-ended
External parts	2 inductors + 1 transformer	✓ Zero	✓ Zero
RF range (GHz)	0.4 to 0.9 (8-phase)	0.1 to 2.4 (8/4-phase)	0.08 to 2.7 (8-phase)
Power (mW) @ RF (GHz)	49 @ 0.4 60 @ 0.9	37 @ 0.1 70 @ 3	37 @ 0.08 70 @ 2.7
DSB NF (dB)	4 ± 0.5	4 to 7	✓ 1.9 ± 0.4
0 dBm blocker NF (dB)	N/A	N/A	✓ 4
Ultimate out-of-band IIP3 (dBm)	+16	✓ +25	+13.5
Ultimate out-of-band IIP2 (dBm)	+56	+56	+54
Active area (mm ²)	1	2	1.2
BB filtering style	2 real poles (active-RC)	2 real poles (active/passive-RC)	2 real poles (active/passive-RC)
HRR _{3,5} (dB)	✓ 60, 64	35, 42	42, 45
BB bandwidth (MHz)	12	N/A	2
RF-to-IF gain (dB)	34.4 ± 0.2	40 to 70	72
Supply (V)	1.2	1.2, 2.5	1.3
CMOS technology	65 nm	65 nm	40 nm

II. Design Challenges and Tradeoffs of Wideband Receivers

The basic architecture of a wideband receiver is depicted in Fig. 1. Without SAW filtering, a weak RF signal (e.g., -100 dBm) can be surrounded by high-power blockers (e.g., 0 dBm). Thus, the instantaneous dynamic range of the

receiver becomes extremely exhaustive, especially under the low-voltage constraints (e.g., 1 V) of ultra-scaled CMOS. To cope with the sensitivity, the receiver might be headed by a LNA (gain: $G_{m,LNA}$), while exploiting a set of highly-linear passive mixers (M_P) for frequency downconversion. To cover or be tunable over a wide range of spectrum,

high-Q LC-resonant-based LNA techniques can hardly be applied due to its area impact. While most wideband topologies, such as the common-gate (CG) LNA, suffer from an inflexible tradeoff between NF, $G_{m,LNA}$ and input impedance ($Z_{in,LNA}$), that must be matched to 50Ω . Alternatively, input impedance matching can be directly provided by the passive mixers, rendering the LNA removable from the receiver to enhance the linearity. However, leaking of RF gain will directly pressure the noise performance of the BB circuitry.

The LNA's output impedance ($Z_{out,LNA}$), and the impedance looking into M_P ($Z_{in,mix}$) pose another tradeoff between NF and linearity. To favor the NF, the LNA should deliver a high-swing output (i.e., big $Z_{out,LNA}$ and $Z_{in,mix}$) to relax the noise contribution of M_P and the back-end circuitry. However, any high-power blockers can easily saturate the LNA's output. Instead, a small-swing output (i.e., big $Z_{out,LNA}$ but small $Z_{in,mix}$) can help to preserve the linearity before adequate filtering is applied at the baseband (BB). However, a big $Z_{out,LNA}$ can hardly be achieved with nm-length MOSFETs due to the strong channel-length modulation, especially when $G_{m,LNA}$ should be high enough to lower the NF, and there is no voltage headroom to apply the cascode topologies. Furthermore, a small $Z_{in,mix}$ implies a big device size for M_P , demanding high drivability (i.e., power) from the local oscillator (LO) path.

M_P under hard-switching [5] is equivalent to a square-wave LO mixed with the input. For high linearity and harmonic rejection, M_P can be expanded to build an N-path mixer, approximating a pseudo-sine-LO with less harmonic contents. Driven by a succession of non-overlapped $1/N$ -duty-cycled LO, the unwanted LO-mixing terms can be rejected by harmonic recombination (HR) at the back-end via proper weighting and summing (e.g., $N = 8$ allows rejection of the 2nd to 6th LO harmonics). Depending on the frequency range of coverage, the value of N has to tradeoff the complexity and power of the LO generation circuitry with the harmonic-rejection ability of the receiver.

Due to the bidirectional frequency-translation property of passive mixing, the input impedance ($Z_{in,LPF}$) of the lowpass filter (LPF) is crucial to the operation of the LNA, i.e., a high $Z_{in,LPF}$ for the voltage mode and a small

$Z_{in,LPF}$ for the current mode. The popular LPF topologies are G_m -C that features high $Z_{in,LPF}$ and low power but moderate linearity, and active-RC that has low $Z_{in,LPF}$ and good linearity but is less power efficient.

III. Circuit Principles for Enhancing Wideband Receivers

This section introduces three circuit principles that can enhance the key performance metrics of wideband receiver: noise cancelling to improve the NF, N-path filtering to enhance the out-of-band linearity, and N-path mixing to realize harmonic rejection.

A. Noise Cancelling

The noise cancelling technique [6] alleviates the tradeoff between input impedance matching and NF. The basic concept is illustrated in Fig. 2(a). Under a source impedance of R_s , the gain of the matching amplifier stage (main path) is constrained by the impedance-matching condition, but the voltage-sensing amplifier stage (auxiliary path) is free to provide a higher gain. Thus, properly combining their outputs can add up the signal while cancelling the noise of the main path, resulting in better NF.

Table 2.
Performance summary of voltage-mode passive-mixer wideband receivers.

	J. Borremans et al. [15] VLSI'13	C. Andrews et al. [16] JSSC'13
Architecture	Voltage mode, passive mixer	
RF input style	Differential	Single-ended
External parts	At least 1 transformer	✓ Zero
RF range (GHz)	✓ 0.4 to 3 (8-phase)	0.7 to 1.6 (8-phase)
Power (mW) @ RF (GHz)	20 @ 0.4 40 @ 3	✓ 10~12 @ 0.7 ✓ 10~12 @ 1.6
DSB NF (dB)	✓ 1.8 to 2.4	10.5 ± 2.5
0 dBm blocker NF (dB)	14	N/A
Ultimate out-of-band IIP3 (dBm)	+3	+10
Ultimate out-of-band IIP2 (dBm)	+85 (calibrated)	+26.6
Active area (mm ²)	✓ ~0.5 (from Fig.)	2.9 (inc. VCOs)
BB filtering style	2 real poles (active/passive-RC)	1 real poles (passive-RC)
HRR _{3,5} (dB)	✓ 70,55 (calibrated)	34, 34
BB bandwidth (MHz)	✓ 0.5 to 50	20
RF-to-IF gain (dB)	36	37
Supply (V)	0.9	1.3
CMOS technology	28 nm	65 nm

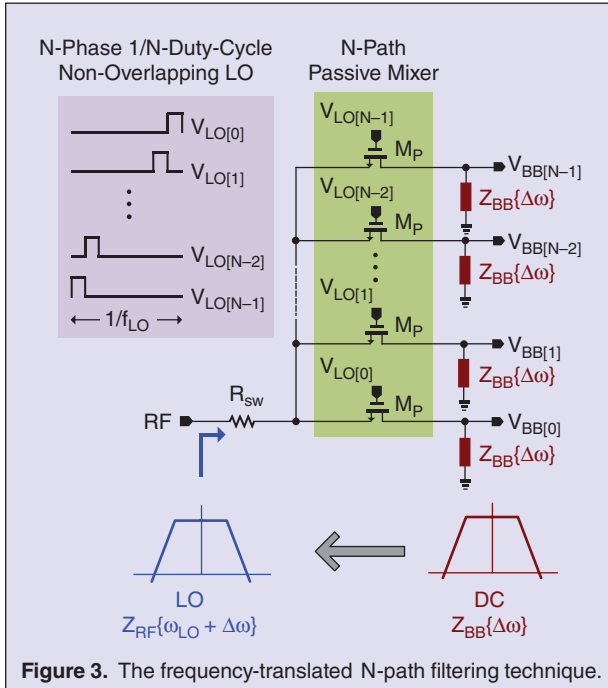

negative voltage is formed at the load resistor R_{CS} via M_{CS} . For the noise of M_{CG} , it appears as a common-mode noise at the output that can be cancelled differentially. Full noise cancelling of M_{CG} occurs under the condition: $R_{CG} = g_{m,CS}R_S R_{CS}$, where $g_{m,CS}$ is the transconductance of M_{CS} . This mechanism can be extended to the receiver level, having one main receiver and one auxiliary receiver with the noise of the former cancelled at the output [7, 8]. This architecture will be discussed later.

B. N-Path Filtering

As shown in Fig. 3, the N-path filtering technique is based on the parallel N-path combination of switch (M_P) clocked by an N-phase non-overlapped LO, and N sets of BB impedance (Z_{BB}). This kind of frequency-translated N-path filter can be served as a current-driven mixer [9], or a high-Q RF filter [10] as it can be directly connected to the antenna for input impedance matching due to its transparency property [11, 12]. With the switch's on-resistance modeled as R_{SW} , the input impedance at RF (Z_{RF}) can be derived as [2, 11]:

$$Z_{RF}\{\omega_{LO} + \Delta\omega\} \approx R_{SW} + \frac{1}{N} \text{sinc}^2\left(\frac{\pi}{N}\right) \cdot Z_{BB}\{\Delta\omega\} \quad (1)$$

From (1), Z_{RF} is a scaled and frequency-translated copy of Z_{BB} . As a result, a lowpass profile of Z_{BB} can be used to realize a bandpass profile at RF for narrowband input impedance matching, while rejecting the out-of-band blockers. In general, for high linearity, Z_{BB} can be simply a capacitor, or a parallel of resistor and capacitor. The center frequency of Z_{RF} is conveniently defined by the LO frequency.

C. N-Path Mixing [Plus Harmonic Recombination (HR)]

Mixers under hard switching minimize the NF and nonlinearity but implying that the blockers at multiple LO frequencies (such as 3rd, 5th...) will also be downconverted to the BB corrupting the desired signal. The original one-stage N-path mixer [13] for harmonic rejection is depicted in Fig. 4(a). Three square-wave LOs with phases of 0° , 45° and 90° can be weighted by $\{1:\sqrt{2}:1\}$ before summing to generate a quantized sinewave to reject the most critical 3rd and 5th LO harmonics. However, this one-stage approach has two drawbacks: 1) the irrational number $\sqrt{2}$ is difficult to be implemented accurately in the layout, and 2) the harmonic rejection ratio (HRR) is sensitive to both gain and phase mismatches, i.e., 1° phase and 1% gain errors will limit the HRR to around 35 dB.

The two-stage N-path mixing and recombination technique [2] can improve HRR to a large extent as shown in Fig. 4(b). The irrational ratio $\{1:\sqrt{2}:1\}$ is realized in two iterative steps with integer numbers: first step with

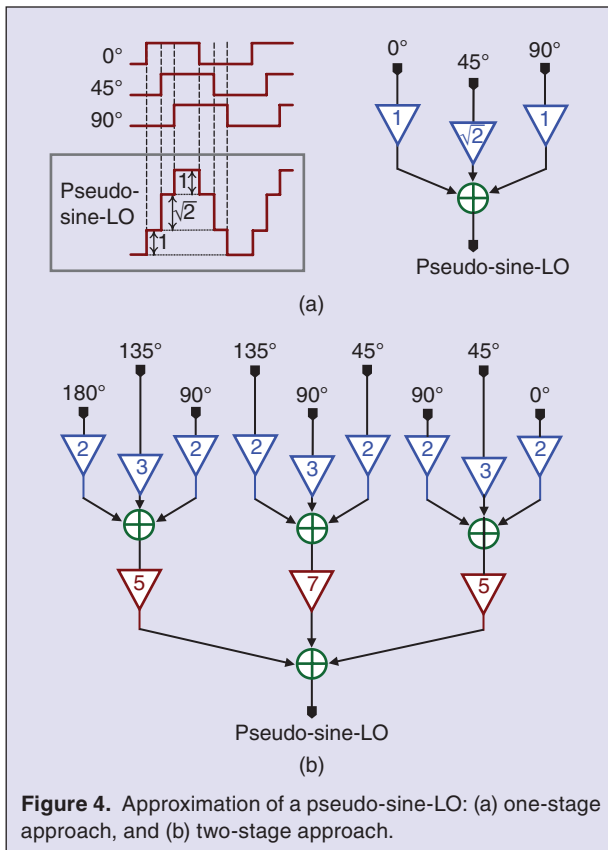

This principle can be implemented as a common-gate common-source (CG-CS) LNA as shown in Fig. 2(b). The input RF current passes through M_{CG} to generate a positive voltage at the load resistor R_{CG} . Meanwhile, a

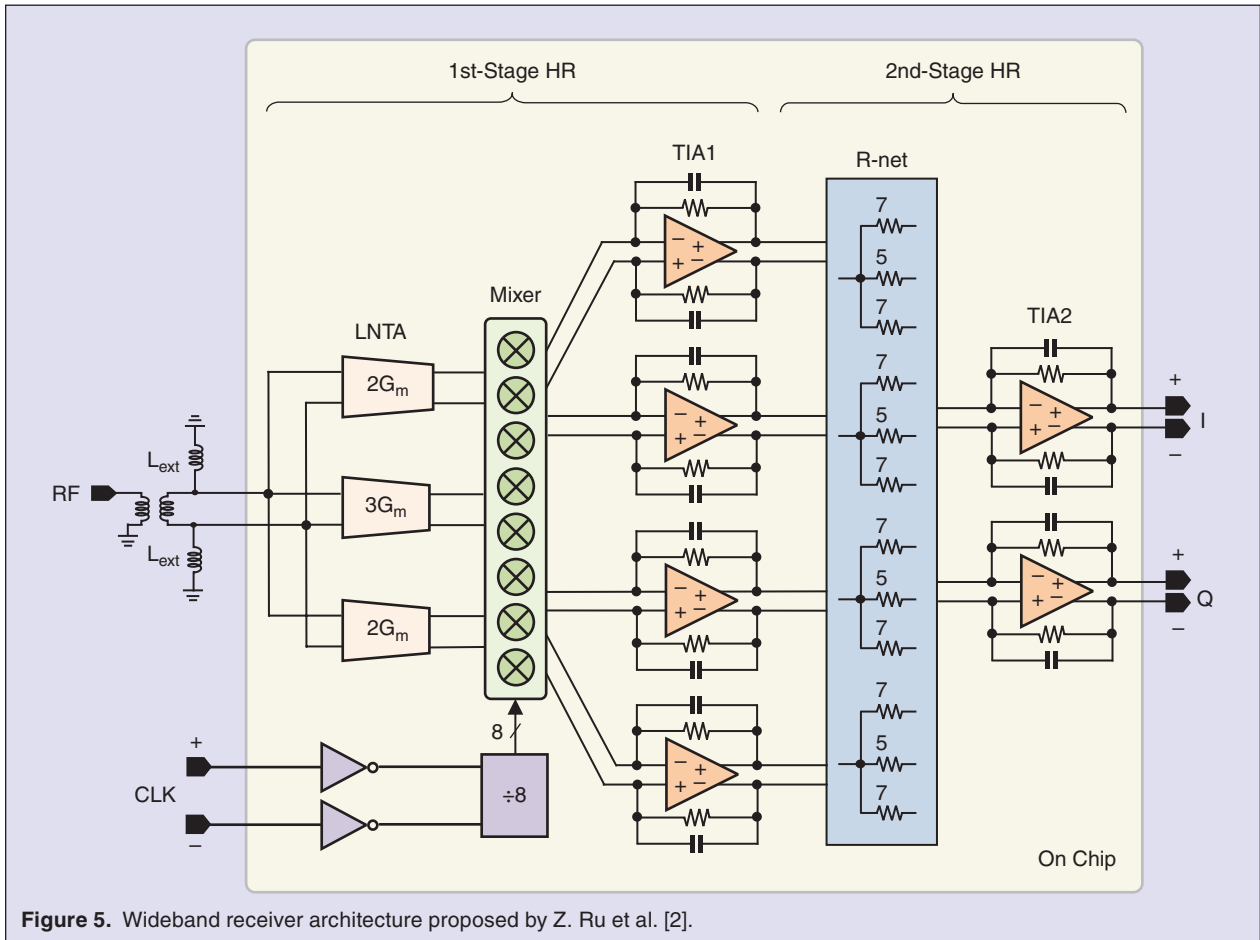

Figure 5. Wideband receiver architecture proposed by Z. Ru et al. [2].

Table 3.
Performance summary of current-mode passive-mixer and active/passive-mixer wideband receivers.

	S. Blaakmeer et al. [17] ISSCC'08	F. LIN et al. [18] ISSCC'14
Architecture	Current mode, active mixer	Current mode, passive/active mixer
RF input style	Single-ended	Single-ended
External parts	1 inductor	✓ Zero
RF range (GHz)	✓ 0.5 to 7 (4-phase)	0.15 to 0.85 (8-phase)
Power (mW) @ RF (GHz)	20 @ 0.5 44 @ 7	✓ 10.6 @ 0.15 ✓ 16.2 @ 0.85
DSB NF (dB)	5 ± 0.5	4.6 ± 0.9
0 dBm blocker NF (dB)	N/A	N/A
Ultimate out-of-band IIP3 (dBm)	-3 (in-band)	✓ +17.4
Ultimate out-of-band IIP2 (dBm)	+20 (in-band)	✓ +61
Active area (mm ²)	✓ 0.01	0.55
BB filtering style	1 real poles	2 complex poles +2 stopband zeros
HRR _{3,5} (dB)	N/A	>53, >51
BB bandwidth (MHz)	400 (area related)	9
RF-to-IF gain (dB)	18	51 ± 1
Supply (V)	1.2	1.2, 2.5
CMOS technology	65 nm	65 nm

Wideband radio frequency (RF) techniques have emerged as the major direction to realize the next generation wireless multi-standard products in expensive nm-length CMOS technologies.

Table 4.
Key features of state-of-the-art wideband receivers.

	Operation Mode	Down-Conversion	Key Circuit Techniques	External Component	Blocker Tolerant	NF	O-IIP3	HRR	Power
Z. Ru et al. ISSCC'09 [2]	Current	Passive mixer	N-path mixing Two-stage HR				✓	✓	
C. Andrews et al. ISSCC'10 [3]	Current	Passive mixer	N-path mixing	✓			✓		
D. Murphy et al. ISSCC'12[7]	Current	Passive mixer	Noise cancelling N-path mixing	✓	✓	✓	✓		
J. Borremans et al. VLSI'13 [15]	Voltage	Passive mixer	N-path filtering			✓		✓	
C. Andrews et al. JSSC'13 [16]	Voltage	Passive mixer	N-path filtering	✓					✓
S. Blaakmeer et al. ISSCC'08 [17]	Current	Active mixer	Noise cancelling						
F. Lin et al. ISSCC'14 [18]	Current	Active// passive mixer	Noise cancelling, Two-stage HR, N-path filtering	✓			✓		✓

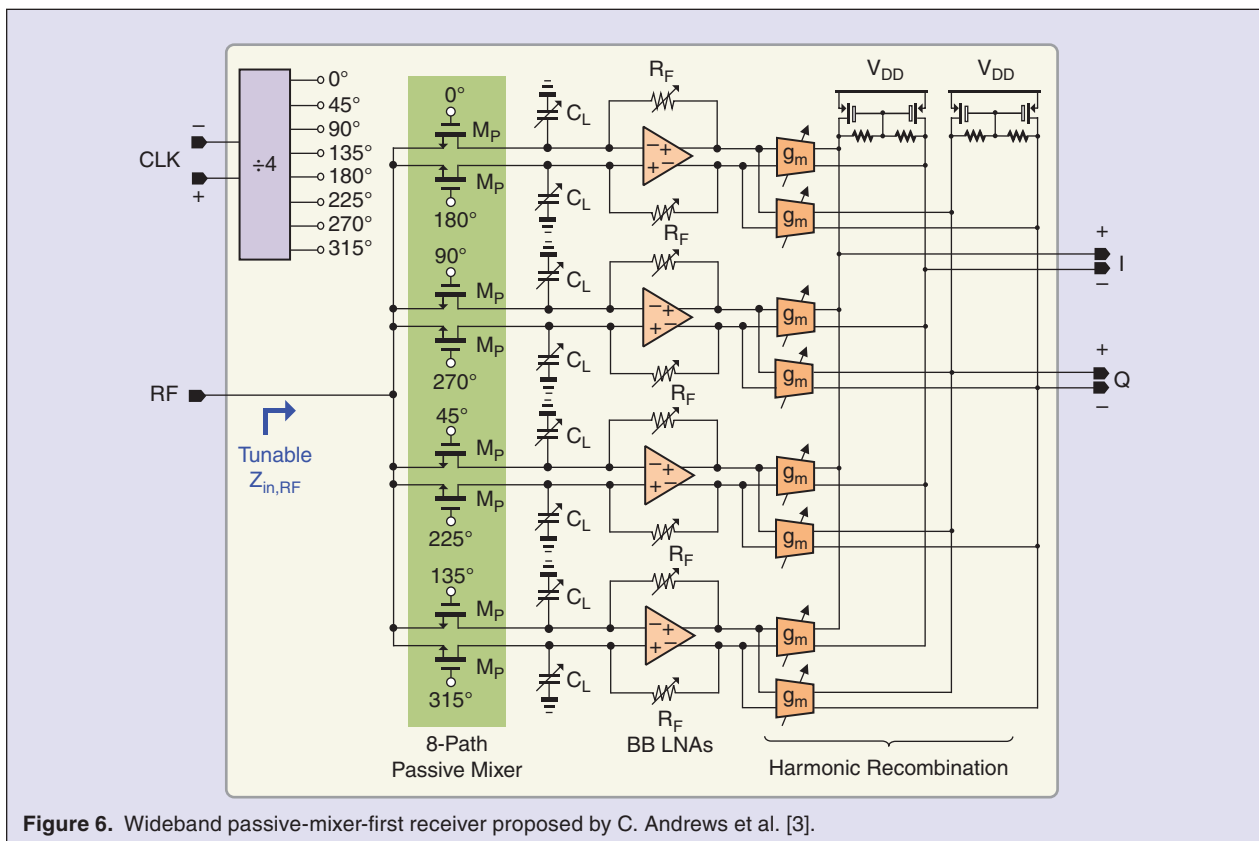

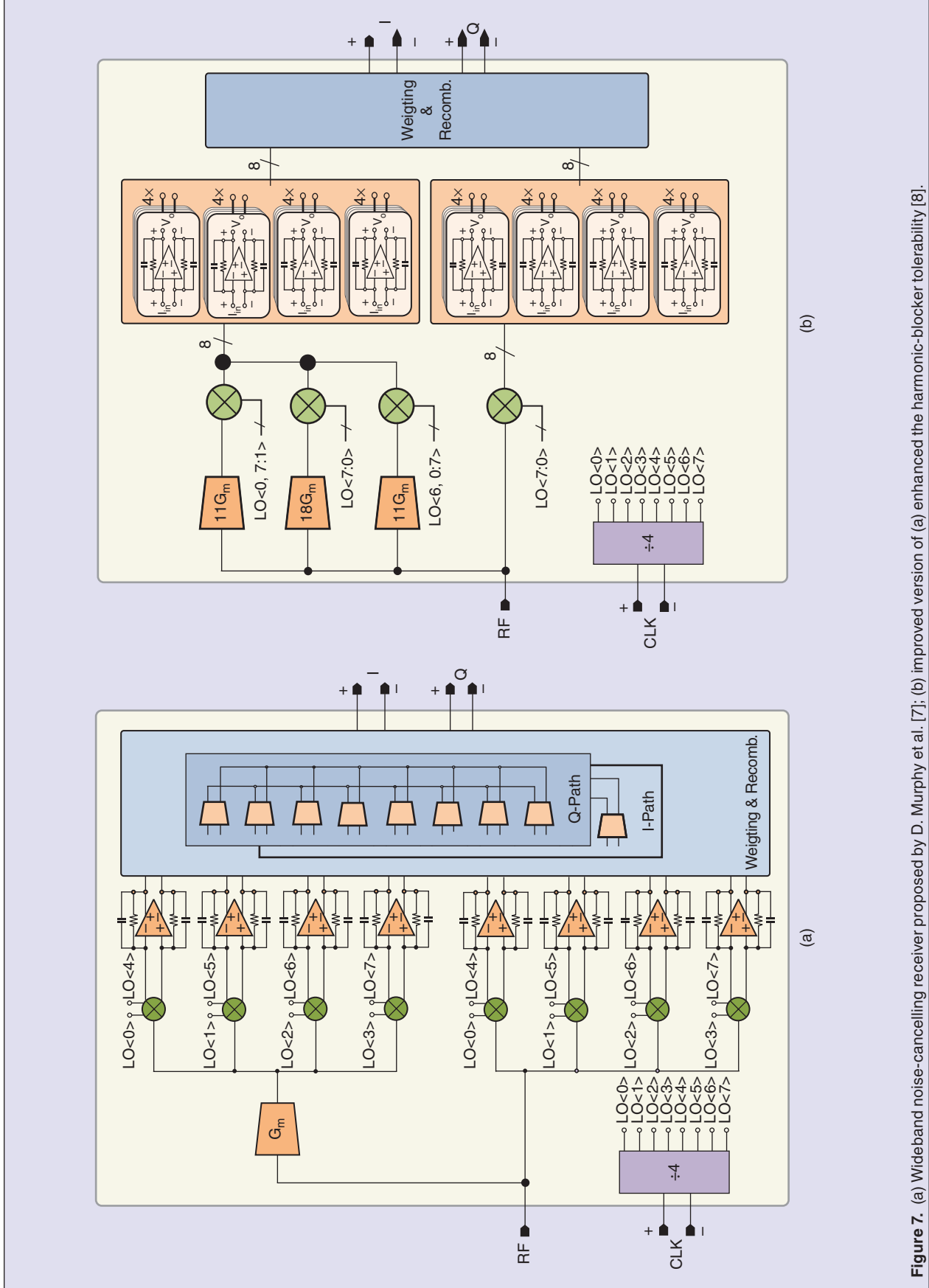

Figure 7. (a) Wideband noise-cancelling receiver proposed by D. Murphy et al. [7]; (b) improved version of (a) enhanced the harmonic-blocker tolerability [8].

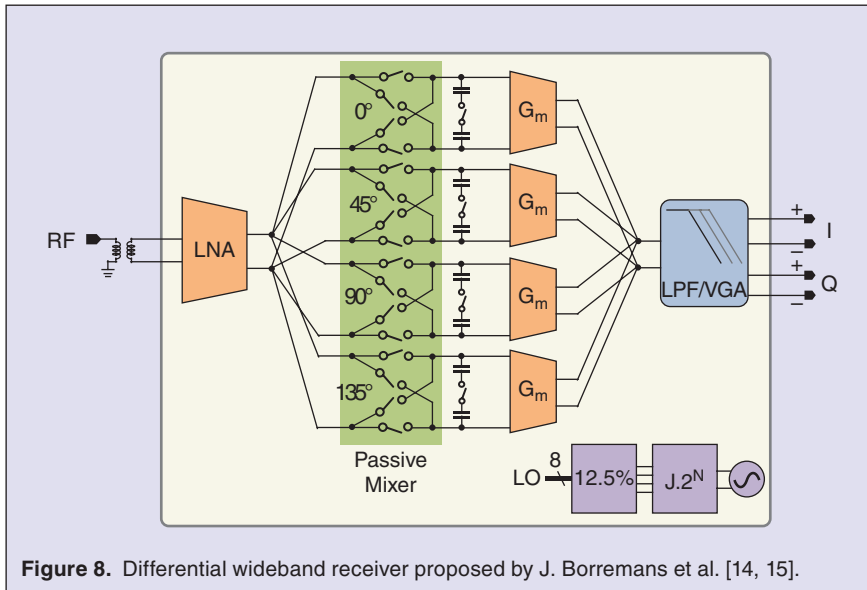

Figure 8. Differential wideband receiver proposed by J. Borremans et al. [14, 15].

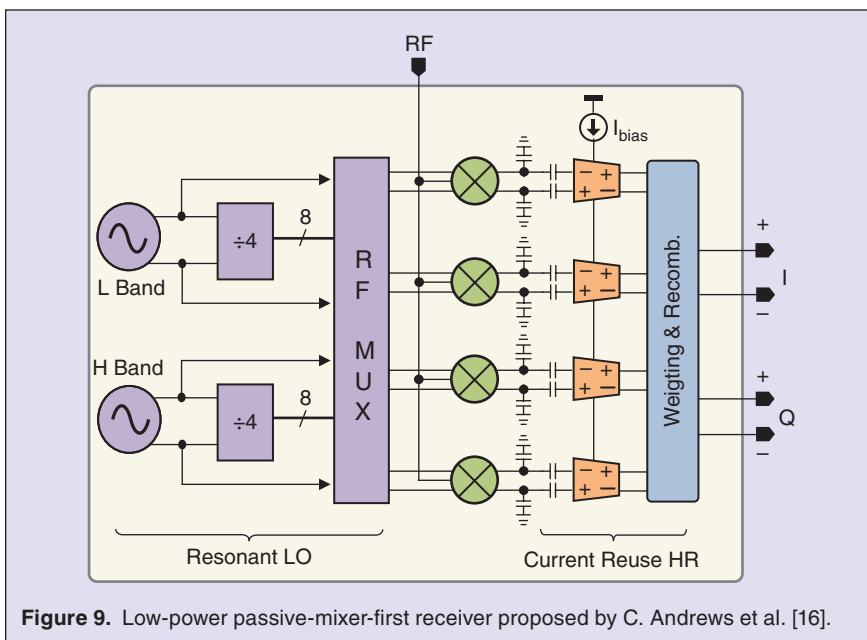

Figure 9. Low-power passive-mixer-first receiver proposed by C. Andrews et al. [16].

2 : 3 : 2 and second step with 5 : 7 : 5. It achieves a weighting ratio of {29 : 41 : 29}, which represents only 0.028% error from the ideal case, corresponding to a HRR of 77 dB theoretically. Another advantage of it is the robustness to gain error. The gain error is determined by the product of the errors from the two stages (α, β). The total relative gain error is deduced as:

$$\frac{2\alpha\beta}{2 \cdot (2 + \alpha) \cdot (2 + \beta)} \approx \frac{\alpha}{2} \cdot \frac{\beta}{2} \quad (2)$$

Thus, the gain error is significantly reduced after multiplication.

IV. State-of-the-Art Wideband Receivers—Case Studies and Classification

According to the operating conditions of the mixer being used to downconvert the RF signal to BB, the wideband receivers can be classified into i) current-mode passive-mixer receiver; ii) voltage-mode passive-mixer receiver; iii) current-mode active-mixer receiver, and iv) current-mode parallel active/passive-mixer receiver.

A. Current-Mode Passive-Mixer Receiver

Z. Ru et al. [2]: Fig. 5 shows its receiver architecture. It entails one off-chip transformer and two off-chip inductors for the differential transconductance low-noise amplifiers (LNTAs). The down-conversion is based on an 8-path current-mode passive mixer, and the BB LPFs are realized by transimpedance amplifiers (TIAs). This topology behaves like a frequency-translated RF-to-BB LNA with the BB virtual ground frequency-translated to RF, absorbing both the in-band signal and out-of-band interferers. The signal amplification and channel selection are delayed to BB, resulting in high linearity. The use of an 8-path two-step topology improves the HRR as described in Section III-C. A div-by-8 circuit generates the 8-phase 12.5%-duty-cycle LO with a high phase accuracy ($<0.07^\circ$ at 0.8 GHz).

C. Andrews et al. [3]: The work (Fig. 6) reveals that the front-end G_m stage can be removed to enhance the linearity, and the BB impedance can be adjusted to realize a tunable $Z_{in,RF}$. LO-defined input impedance matching is achieved with zero external components, while achieving a high out-of-band IIP3 of +25 dBm. Without the RF gain, the BB LNAs will demand more power to suppress its input-referred noise. The HR is solely realized at BB with a single-stage approach to suppress the 3rd and 5th LO harmonics.

D. Murphy et al. [7, 8]: This work [Fig. 7(a)] combines the basic principles of [2] and [3] in an effective parallel approach to achieve concurrently low NF and high

linearity, constituting a noise-cancelling receiver suitable for wideband applications. It consists of two paths: main and auxiliary. The noise contribution of the main path (mixer-first path) can be completely cancelled after being subtracted from the auxiliary path at the differential output. G_m is the only significant noise source of the receiver, i.e., more power allocated to G_m can improve the NF. G_m can be simply an inverter amplifier, which is low noise and can tolerate large blockers. An improved version of it [8] has been reported to enhance the tolerability of blockers located at the LO harmonics [Fig. 7(b)]. This receiver employs a harmonic-rejection TIAs that prevent amplification of harmonic blockers at the TIA outputs. Since each HR-TIA is composed of four rotational BB TIA cells, both circuit complexity and die area are penalized to some extents when comparing with [2, 3, 7].

Discussion: The key performances of the three current-mode passive-mixer-based receivers [2, 3, 7] are given in Table 1. The 65-nm receiver by Z. Ru et al [2] shows good wideband performances such as high out-of-band IIP3 of +16 dBm and high HRR of 60 dB, but the power consumption is as large as 60 mW at 0.9 GHz at 1.2 V. The RF port also requires numerous external components. The passive-mixer-first receiver by C. Andrews et al [3] shows a higher out-of-band IIP3 of +25 dBm and entails no external components for input matching. However, due to the absence of RF gain, the NF (4 to 7 dB) is inferior in the covered frequency range. The BB circuitry consumes significant power (30 mW) to ensure low NF and requires a 2.5-V supply to

enhance the dynamic range. The noise-cancelling receiver by D. Murphy et al [7] achieves the lowest NF (<2 dB) among all, and reports an impressive 0-dBm blocker NF of 4 dB. Although two receiver paths are employed, the power is comparable with [3], thanks to the reduced supply (1.3 V) and the advancement of technology (40 nm).

B. Voltage-Mode Passive-Mixer Receiver

J. Borremans et al. [14, 15]: Its architecture is shown in Fig. 8. It employs a differential LNA followed by an 8-path passive mixer and a set of BB gain stage (G_m) before applying the LPF and gain control. Unlike the current-mode passive-mixer receivers [2, 3, 7], the power-efficient G_m -C circuitry shows a lowpass RC input impedance rather than a virtual ground. Such a lowpass response at BB will be frequency-translated as a bandpass one at the LNA's output, rejecting the out-of-band blockers at RF. A high supply voltage with protection circuits [14] and the use of an advanced 28-nm technology [15] can benefit the performance. Because of the voltage-mode operation of the LNA, this receiver is more power efficient than [2, 3, 7] but has lower linearity.

C. Andrews et al. [16]: Another voltage-mode passive-mixer receiver [16] is presented in Fig. 9. Its power is significantly cut down by operating the passive mixer in the voltage mode (i.e., no virtual ground at BB and RF), and using resonant multi-phase LO and current-reuse harmonic rejection at BB. The multiple voltage-controlled oscillators (VCOs) directly drive the mixer through a RF multiplexer (MUX) for saving LO power (8 to 10 mW), covering a wider frequency

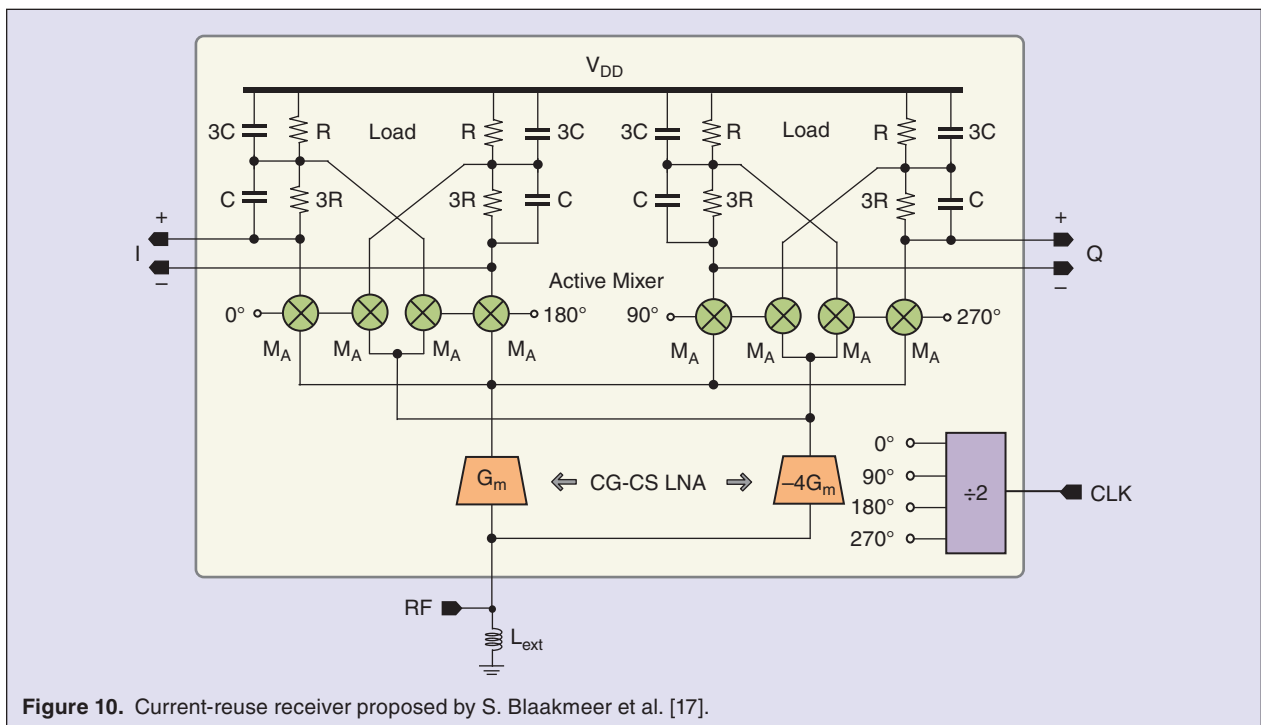

Figure 10. Current-reuse receiver proposed by S. Blaakmeer et al. [17].

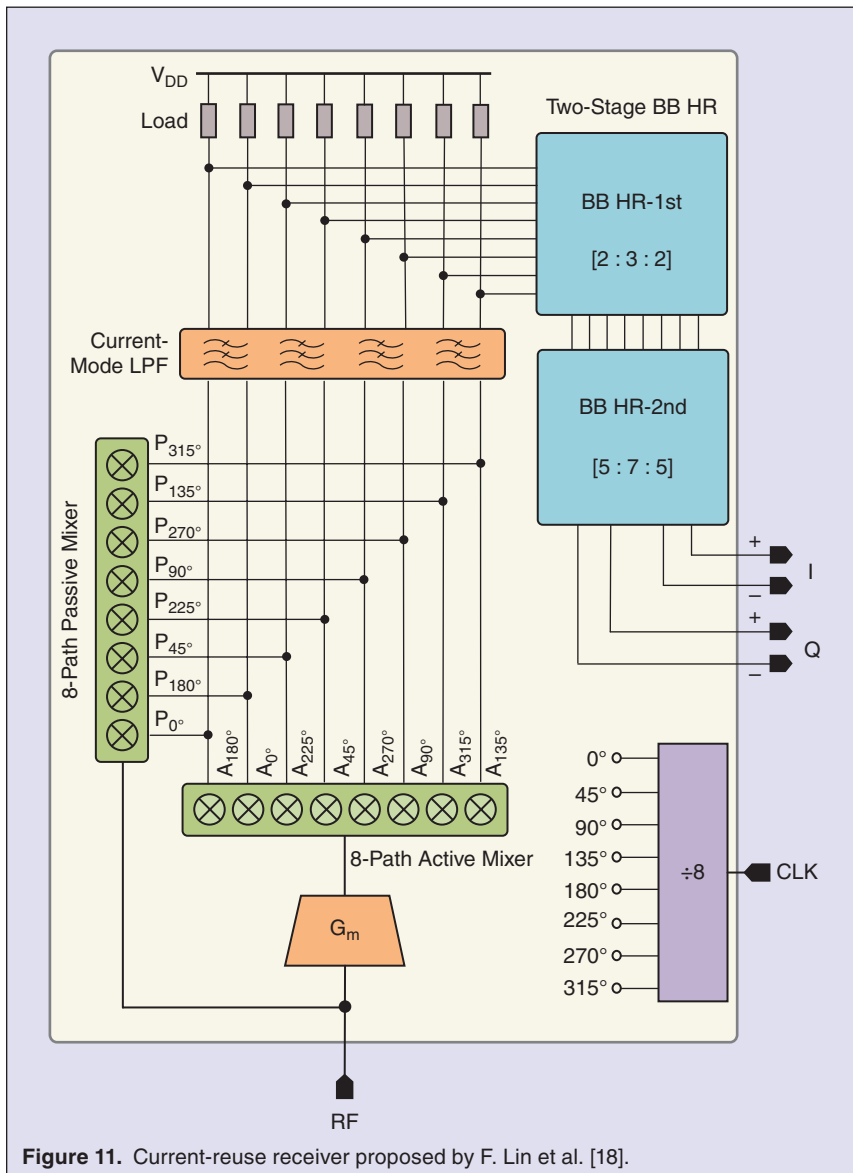

Figure 11. Current-reuse receiver proposed by F. Lin et al. [18].

range of 0.7 to 3.2 GHz. Because of no RF gain and degraded LO waveforms, performances are much penalized when compared with the current-mode passive-mixer receiver [3].

Discussion: The performances of such two voltage-mode passive-mixer receivers are given in Table 2. The 28-nm CMOS differential receiver by J. Borremans et al. [15] requires at least one wideband external transformer. Due to its voltage-mode operation, the receiver achieves a NF <3 dB and power <40 mW, but the out-of-band IIP3 is degraded (+3 dBm). The work by C. Andrews et al [16] penalizes both NF (7 to 13 dB) and IIP3 (+10 dBm) as a tradeoff with the power (10 to 12 mW). The power is reduced by more than 20 mW when compared with [15]. In general, the reported voltage-mode receivers show 10 dB less IIP3 when compared with its current-mode counterparts [2, 3].

of-band linearity and a BB-only two-step HR amplifier boosts the HRR and BB signal swing with low hardware intricacy.

Discussion: The current-mode active-mixer receiver and parallel active/passive-mixer receiver are compared in Table 3. The single-ended receiver by S. Blaakmeer et al. [17] entails an external inductor for input matching and biasing. Meanwhile, it suffers from a lower IIP3 (−3 dBm) than the passive-mixer receivers [2, 3] owing to the lack of frequency-translated bandpass filtering. The work by F. Lin et al. [18] employs mixed-voltage design [4] to optimize the power consumption (10.6 to 16.2 mW), while achieving low NF (4.6±0.9 dB), high out-of-band IIP3 (+17.4 dBm) and high HRR (>51 dB).

D. Summary

Table 4 benchmarks the state-of-the-art wideband receivers. Designs employing passive mixers for input matching

C. Current-Mode Active-Mixer Receiver and Current-Mode Parallel Active/Passive-Mixer Receiver

S. C. Blaakmeer et al. [17]: Differing from passive-mixer receivers, the active mixer can bridge the RF and BB in a single current-reuse cell, offering a potential alternative to save the overall power as shown in Fig. 10. It consists of a common-gate-common-source (CG-CS) LNA with admittance scaling of 1:4 for better NF and active mixer (M_A) for current-mode downconversion, and BB RC filters for current-to-voltage conversion. By processing the RF signal in the current domain, the effect of out-of-band blockers can be mitigated. Such a topology owns the drawbacks of low filtering orders and limited voltage headroom. Meanwhile, the 4-path mixing offers no harmonic rejection.

F. Lin et al. [18]: This receiver employs an RF-to-BB current-reuse topology (Fig. 11) to merge the beneficial properties of both passive and active mixers. The N-path passive mixer realizes the input matching, out-of-band filtering, input biasing and noise cancelling, while the N-path active mixer enables the full current-reuse structure for power savings. In addition, a current-mode single-MOS LPF is cascoded for strong BB filtering to enhance out-

[3, 7, 18, 18] own the advantage of zero external components but have a higher risk of LO re-radiation. Overall, the current-mode passive-mixer receivers [2, 3, 7, 18] show better out-of-band IIP3 than the voltage-mode [15, 16] and active-mixer [17]. The noise-cancelling receiver [7] has the lowest NF and the strongest blocker tolerability. The NF can be improved by the LNA [15] in the voltage mode. The work [16] employing resonant LO can save much power but penalizing the NF and linearity. The active-mixer receiver [17] allows power savings, but the out-of-band linearity is limited at RF. The parallel N-path passive/active-mixer receiver [18] improves the RF linearity at low power. Finally, receivers employing the two-step HR technique [2] own better HRR capability than those with only one-step design.

V. Conclusions

As universal wideband receivers emerge as the most power- and area-efficient solution to underpin multi-band multi-standard wireless communications, the involved design challenges and tradeoffs have to be understood clearly when projecting further developments. This article only serves as a glimpse of this research trend, while consolidating the necessary system considerations when applying the available techniques. Specifically, the basic principles of noise cancelling, N-path filtering and N-path mixing are reviewed. They are the key techniques notably improving the performance metrics of wideband receivers in the recent years. Moreover, by examining the architectural pros and cons of state-of-the-art CMOS wideband receivers, they can be easily compared and classified as current-mode passive-mixer receiver, voltage-mode passive-mixer receiver, current-mode active-mixer receiver and current-mode parallel active/passive-mixer receiver. After all, compact BB circuitry and power-efficient multi-phase LO generation circuits [19, 20] are considered as the remaining area and power bottlenecks of wideband receivers to expand the frequency coverage and lower the cost. These open problems will challenge all RF designers in this evolving field in the years to come.

Acknowledgments

This research was financially supported by the Macao Science and Technology Development Fund (FDCT) and the Research Committee of University of Macau: MYRG114(Y1-L4)-FST13-MPI.



Fujian Lin received the B.Sc. degree in Electronic Science and Technology from North University of China, Shanxi Province, China in 2004 and M.Sc. degree in Micro-electronics and Solid-state Electronics with specialization in high performance low power

analog integrated circuits from Institute of Microelectronics of Chinese Academy of Sciences, Beijing, China in 2008, respectively. From year 2008 to 2010, he worked on audio power amplifiers (APAs) such as Class AB and Class D, and power management ICs (PMICs) such as DC/DC and Li-ion Battery Charger for consumer electronics applications, in Microelectronics and System Engineering Center of Jiaxing Research and Commercialization Center for Technology of Chinese Academy of Sciences, Jiaxing City, Zhejiang Province, China. He currently is working towards the Ph.D. degree at the State-Key Laboratory of Analog and Mixed-Signal VLSI and FST-ECE, University of Macau, Macau, China. His current research focuses on RF circuit technique for wideband software-defined radio front-ends.



Pui-In Mak (S'00-M'08-SM'11) received the Ph.D. degree from University of Macau (UM), Macao SAR, China, in 2006. He is currently Associate Professor at UM, and Coordinator of the Wireless & Biomedical Research Lines of the *State Key Laboratory of Analog and Mixed-Signal VLSI*. His research interests are on analog and RF circuits and systems for wireless, biomedical and physical chemistry applications. His group reported 6 state-of-the-art chips at ISSCC: wideband receivers (2011, 2014), micro-power amplifiers (2012, 2014) and ultra-low-power Zig-Bee receivers (2013, 2014), and pioneered the world's first *Intelligent Digital Microfluidic Technology (iDMF)* with Nuclear Magnetic Resonance (NMR) and Polymerase Chain Reaction (PCR) capabilities. He authored 2 books: *Analog-Baseband Architectures and Circuits for Multistandard and Low-Voltage Wireless Transceivers* (Springer'07), and *High-/Mixed-Voltage Analog and RF Circuit Techniques for Nanoscale CMOS* (Springer'12). His involvements with IEEE are: Distinguished Lecturer ('14-'15) and Member of Board-of-Governors ('09-'11) of IEEE Circuits and Systems Society (CASS); Editorial Board Member of IEEE Press ('14-'16); Senior Editor of *IEEE Journal on Emerging and Selected Topics in Circuits and Systems* ('14-'15); Associate Editor of *IEEE Transactions on Circuits and Systems I (TCAS-I)* ('10-'11, '14-'Present); Associate Editor of *IEEE Transactions on Circuits and Systems II (TCAS-II)* (10-'13), and Guest Editor of *IEEE RFIC Virtual Journal* ('14) for the issue of LNA. He is a TPC member of A-SSCC. Prof. Mak received IEEE DAC/ISSCC Student Paper Award'05; IEEE CASS Outstanding Young Author Award'10; National Scientific and Technological Progress Award'11; Best Associate Editor for *TCAS-II* '12-'13. In 2005, he was decorated with the *Honorary Title of Value* for scientific merits by the Macau Government.



Rui P. Martins (M'88-SM'99-F'08), born in April 30, 1957, received the Bachelor (5-years), the Masters, and the Ph.D. degrees, as well as the *Habilitation* for Full-Professor in electrical engineering and computers from the Department of Electrical and Computer Engineering, Instituto Superior Técnico (IST), TU of Lisbon, Portugal, in 1980, 1985, 1992 and 2001, respectively. He has been with the Department of Electrical and Computer Engineering (DECE)/IST, TU of Lisbon, since October 1980. Since 1992, he has been on leave from IST, TU of Lisbon, and is also with the Department of Electrical and Computer Engineering, Faculty of Science and Technology (FST), University of Macau (UM), Macao, China, where he is a Full-Professor since 1998. In FST he was the Dean of the Faculty from 1994 to 1997 and he has been Vice-Rector of the University of Macau since 1997. From September 2008, after the reform of the UM Charter, he was nominated after open international recruitment as Vice-Rector (Research) until August 31, 2013. Within the scope of his teaching and research activities he has taught 21 bachelor and master courses and has supervised (or co-supervised) 26 theses, Ph.D. (11) and Masters (15). He has published: 12 books, co-authoring (5) and co-editing (7), plus 5 book chapters; 266 refereed papers, in scientific journals (60) and in conference proceedings (206); as well as other 70 academic works, in a total of 348 publications. He has also co-authored 7 US Patents. He has created the *Analog and Mixed-Signal VLSI Research Laboratory of UM*: http://www.fst.umac.mo/en/lab/ans_vlsi/website/index.html, elevated in January 2011 to State Key Lab of China (the 1st in Engineering in Macao), being its Founding Director. Prof. Rui Martins is an *IEEE Fellow*, was the Founding Chairman of the IEEE Macau Section from 2003 to 2005, and of the IEEE Macau Joint-Chapter on Circuits And Systems (CAS)/Communications (COM) from 2005 to 2008 [2009 *World Chapter of the Year of the IEEE Circuits And Systems Society (CASS)*]. He was the General Chair of the 2008 IEEE Asia-Pacific Conference on Circuits And Systems—*APCCAS'2008*, and was the Vice-President for the Region 10 (Asia, Australia, the Pacific) of the *IEEE Circuits And Systems Society (CASS)*, for the period of 2009 to 2011. He is now the Vice-President (World) Regional Activities and Membership also of the IEEE CAS Society for the period 2012 to 2013. He is Associate Editor of the *IEEE Transactions on Circuits and Systems II: Express Briefs*, since 2010 and until the end of 2013. Plus, he is a member of the IEEE CASS Fellow Evaluation Committee (Class of 2013). He was the recipient of 2 government decorations: the Medal of Professional Merit from Macao Government (Portuguese Administration) in 1999, and the Honorary Title of Value from Macao SAR

Government (Chinese Administration) in 2001. In July 2010 was elected, unanimously, as Corresponding Member of the Portuguese Academy of Sciences (in Lisbon), being the only Portuguese Academician living in Asia.

References

- [1] P.-I. Mak, S.-P. U, and R. P. Martins, "Transceiver architecture selection—Review, state-of-the-art survey and case study," *IEEE Circuits Syst. Mag.*, vol. 7, no. 2, pp. 6–25, Apr.–June 2007.
- [2] Z. Ru, N. Moseley, E. Klumperink, and B. Nauta, "Digitally enhanced software-defined radio receiver robust to out-of-band interference," *IEEE J. Solid-State Circuits*, vol. 44, no. 12, pp. 3359–3374, Dec. 2009.
- [3] C. Andrews and A. Molnar, "A passive mixer-first receiver with digitally controlled and widely tunable RF interface," *IEEE J. Solid-State Circuits*, vol. 45, no. 12, pp. 2696–2708, Dec. 2010.
- [4] P.-I. Mak and R. P. Martins, "High-/mixed-voltage RF and analog CMOS circuits come of age," *IEEE Circuits Syst. Mag.*, vol. 10, no. 4, pp. 27–39, Dec. 2010.
- [5] B. Razavi, *RF Microelectronics*. Upper Saddle River, NJ: Prentice Hall, 1998.
- [6] F. Bruccoleri, E. Klumperink, and B. Nauta, "Wide-band CMOS low-noise amplifier exploiting thermal noise canceling," *IEEE J. Solid-State Circuits*, vol. 39, no. 2, pp. 275–282, Feb. 2004.
- [7] D. Murphy, H. Darabi, A. Abidi, A. Hafez, A. Mirzaei, M. Mikhemar, and M. Chang, "A blocker-tolerant, noise-canceling receiver suitable for wideband wireless applications," *IEEE J. Solid-State Circuits*, vol. 47, no. 12, pp. 2943–2963, Dec. 2012.
- [8] D. Murphy, H. Darabi, and H. Xu "A noise-cancelling receiver with enhanced resilience to harmonic blockers," in *ISSCC Dig. Tech. Papers*, Feb. 2014, pp. 68–69.
- [9] A. Mirzaei, J. Leete, and Y. Chang, "Analysis and optimization of direct-conversion receivers with 25% duty-cycle current-driven passive mixers," *IEEE Trans. Circuits Syst. I*, vol. 57, no. 9, pp. 2353–2366, Sept. 2010.
- [10] A. Mirzaei, H. Darabi, and D. Murphy, "A low-power process-scalable super-heterodyne receiver with integrated high-Q filters," *IEEE J. Solid-State Circuits*, vol. 46, no. 12, pp. 2920–2932, Dec. 2011.
- [11] C. Andrews and A. Molnar, "Implications of passive mixer transparency for impedance matching and noise figure in passivemixer-first receivers," *IEEE Trans. Circuits Syst. I*, vol. 57, no. 12, pp. 3092–3103, Dec. 2010.
- [12] A. Ghaffari, E. Klumperink, M. Soer, and B. Nauta, "Tunable high-Q N-path band-pass filters: modeling and verification," *IEEE J. Solid-State Circuits*, vol. 46, no. 5, pp. 998–1010, May 2011.
- [13] J. Weldon, R. Narayanaswami, J. Rudell, L. Li, M. Otsuka, S. Dedieu, L. Tee, K.-C. Tsai, C.-W. Lee, and P. Gray, "A 1.75-GHz highly integrated narrow-band CMOS transmitter with harmonic-rejection mixers," *IEEE J. Solid-State Circuits*, vol. 36, no. 12, pp. 2003–2015, Dec. 2001.
- [14] J. Borremans, G. Mandal, V. Giannini, B. Debaillie, M. Ingels, T. Sano, B. Verbruggen, and J. Craninckx, "A 40 nm CMOS 0.4–6 GHz receiver resilient to out-of-band blockers," *IEEE J. Solid-State Circuits*, vol. 46, pp. 1659–1671, July 2011.
- [15] J. Borremans, B. van Liempd, E. Martens, S. Cha, and J. Craninckx, "A 0.9 V low-power 0.4–6 GHz linear SDR receiver in 28 nm CMOS," in *Symp. VLSI Circuits, Dig. Tech. Papers*, June 2013, pp. 146–147.
- [16] C. Andrews, L. Diamente, D. Yang, B. Johnson, and A. Molnar, "A wideband receiver with resonant multi-phase LO and current reuse harmonic rejection baseband," *IEEE J. Solid-State Circuits*, vol. 48, no. 5, pp. 1188–1198, May 2013.
- [17] S. Blaakmeer, E. Klumperink, D. Leenaerts, and B. Nauta, "The Blixer, a wideband balun-LNA-I/Q-mixer topology," *IEEE J. Solid-State Circuits*, vol. 43, no. 12, pp. 2706–2715, Dec. 2008.
- [18] F. Lin, P.-I. Mak, and R. P. Martins, "An RF-to-BB current-reuse wideband receiver with parallel N-path active/passive mixers and a single-MOS pole-zero LPF," in *ISSCC Dig. Tech. Papers*, Feb. 2014, pp. 74–75.
- [19] I. Fabiano, M. Sosio, A. Liscidini, and R. Castello, "SAW-less analog front-end receivers for TDD and FDD," *IEEE J. Solid-State Circuits*, vol. 48, no. 12, pp. 3067–3079, Dec. 2013.
- [20] J. Park and B. Razavi, "A 20mW GSM/WCDMA receiver with RF channel selection," in *ISSCC Dig. Tech. Papers*, Feb. 2014, pp. 356–357.