

A Robust NTF Zero Optimization Technique for both Low and High OSRs Sigma-Delta Modulators

Yun Du, Tao He, Yang Jiang, Sai-Weng Sin, Seng-Pan U¹, R.P.Martins²

State-Key Laboratory of Analog and Mixed Signal VLSI (http://www.fst.umac.mo/en/lab/ans_vlsi/index.html)

Faculty of Science and Technology, University of Macau, Macao, China

E-mail: hughla1987@gmail.com, TerrySSW@umac.mo

1 - Also with Synopsys - Chipidea Microelectronics (Macao) Limited

2 - On leave from Instituto Superior Técnico/TU of Lisbon, Portugal

Abstract— This paper introduces a novel loop filter scheme with embedded noise transfer function (NTF) zero optimization in a feed-forward topology. This new structure allows the relaxation of the requirement of the local feedback coefficient. Moreover, the merit of zero optimization is compatible with high oversampling ratio (OSR) when compared with the traditional loop filter. Besides, the practical implementation exhibits less sensitivity to the capacitor ratio mismatches. A second order discrete-time (DT) sigma-delta ($\Sigma\Delta$) modulator with the proposed loop filter is designed and simulated with Matlab and Cadence. The performance of the modulator can reach 70.1dB/99.3dB SNDR in a 10MHz bandwidth, with OSR 12/48 and the corresponding coefficients in the local feedback 0.4/0.34, respectively.

I. INTRODUCTION

Presently, the demand for analog-to-digital converters with wide signal bandwidth and high resolution has increased quite fast due to their frequent utilization in wire-line and wireless communication systems. As such, the characteristics of the oversampling and strong noise shaping have raised the popularity of the sigma delta modulator in ADC signal processing. To be specific, the quantization noise is highly filtered out of the signal band, which is thus suppressed in the bandwidth by the N-th order noise shaping when compared with Nyquist-rate ADCs. Besides, the matching requirement of analog components is far more relaxed, while still achieving medium to high resolution [1].

There are several methods to boost the SNDR, i.e. either by increasing the order of loop filter or the oversampling ratio (OSR). However, originally in wide-band applications, the OSR cannot be too high because it will increase the power consumption in the amplifiers. Till recently, voltage controlled oscillator based ADCs led to a significant improvement in SNDR for its intrinsic first order noise shaping, and they are greatly fitted for high speed processing with no power budget associated with relatively high OSR [2]. Therefore, OSR will no longer be the bottleneck of wide band applications.

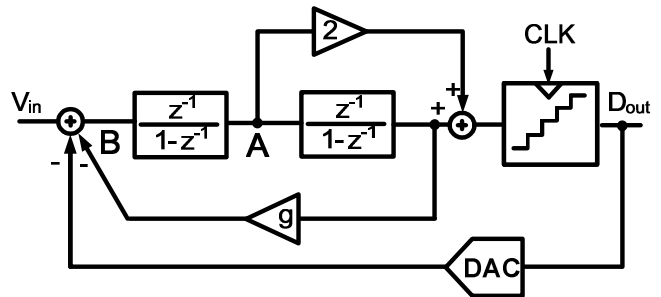

Fig. 1. Traditional 2nd order SDM with zero-optimization feedback.

Meanwhile, to further increase the performance of the ADC, a zero optimization technique is adopted in high order sigma delta modulator. For example in [3] and [4], a local feedback with a small coefficient is introduced in the loop filter for better location of the zeros in the noise transfer function (NTF). Also in [5], a new zero-optimization scheme for noise coupled sigma delta ADCs has been introduced to improve the in-band noise shaping. In these 3 cases, since the local feedback coefficient is inversely proportional to the OSR value, it will imply higher implementation complexity, thus allowing zero optimization only to be feasible for low OSR applications.

In this paper, a novel loop filter of a 2nd order sigma delta modulator with a more robust coefficient in its local feedback is proposed. The merit of the new structure is its compatibility with zero optimization of the relatively low OSR. Besides, it also allows, in practice, the relaxation of the implementation for high values of OSR.

This paper is organized as follows: Section II has the review of zero optimization in traditional second order sigma-delta modulator. Section III introduces the proposed structure together with the new method for optimizing NTF zero, and the circuit design of the proposed structure will also be described. Section IV presents the simulation results, and finally Section V will draw the conclusions.

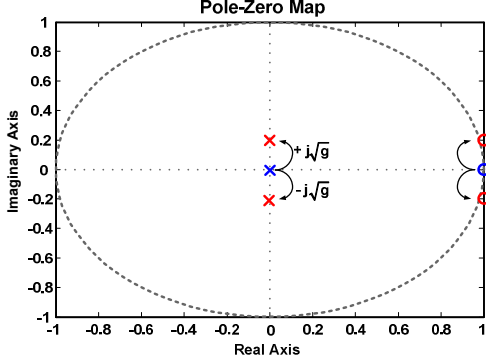

Fig. 2. NTF Pole and Zero location in 2nd order SDM with local feedback.

II. REVIEW OF ZERO-OPTIMIZATION THEORY

The block diagram of a conventional 2nd order $\Sigma\Delta$ modulator using feed-forward topology is depicted in Fig. 1. In this figure, the local negative feedback is introduced from the second integrator output to the first integrator input, which creates a resonator in the loop filter. Thus, the NTF zeros are shifted away from their initial location ($z=1$). The transfer function of the loop filter and the NTF can be expressed as follows:

$$LF(z) = \frac{2z^{-1} - z^{-2}}{(1 - z^{-1})^2 + gz^{-2}} \quad (1)$$

$$NTF(z) = \frac{(1 - z^{-1})^2 + gz^{-2}}{1 + gz^{-2}} \quad (2)$$

In theory, the ideal second order noise transfer function is $NTF(z) = (1 - z^{-1})^2$. The shifting of NTF zeros from $z=1$ to $z=e^{\pm j\alpha}$ will cause the NTF magnitude change from ω^2 to $(\omega - \alpha)^2$ in the pass-band. According to [6], the integral of the square of this quantity over the pass-band is a measure of the in-band noise, as shown in equation (3), where ω_B is the signal bandwidth. Then, to minimize this in-band noise, the optimum value of α should be calculated as in (4).

$$I(\alpha) = \int_0^{\omega_B} (\omega^2 - \alpha^2)^2 \partial\omega \quad (3)$$

$$\alpha_{opt} = \omega_B \cdot \frac{T}{\sqrt{3}} = \pi / (OSR \cdot \sqrt{3}) \quad (4)$$

Then the optimum zero location and value of the local feedback path weight can be found in (5) and (6), respectively.

$$Z_{opt} = 1 \pm j\sqrt{g} \quad (5)$$

$$g_{opt} \approx \alpha_{opt}^2 \approx \pi^2 / (OSR^2 \cdot 3) \quad (6)$$

This approximate calculation of the variation of g_{opt} versus the OSR has been proven in [5]. Additionally, the larger the OSR is, the smaller the value of g_{opt} will be. Thus, there may be difficulties to realize it on chip, in practice, implying that, normally, zero optimization will only be used in low OSR applications. Fig. 2 shows the pole and zero shifting from the original location to the optimized places, which in turn improves the in-band noise shaping.

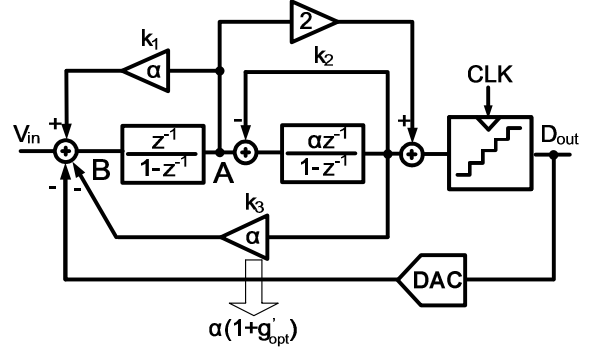

Fig. 3. Proposed 2nd order SDM with relaxed feedback coefficient.

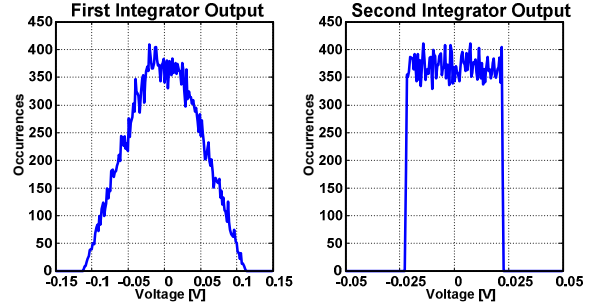

Fig. 4. Output swings of the two integrators.

III. PROPOSED LOOP FILTER FOR ROBUST ZERO-OPTIMIZATION

A. Proposed Scheme for Zero-Optimization

To solve the problems arising from a practical implementation a novel 2nd order loop filter structure is proposed with its block diagram in Fig. 3. Two switched-capacitor integrators functioning as $z^{-1}/(1 - z^{-1})$ are modeled for achieving second order noise shaping. Here, a is the coefficient in the feedback loops. Different from the traditional structure in Fig. 1, two extra local feedbacks k_1 and k_2 , framing on each integrator, are introduced with positive and negative signs, respectively. The resulting loop filter transfer function and therefore NTF are expressed by Eq. (7) and (8) below. If a equals 1/3, then the ideal 2nd order NTF with double poles in the origin will be obtained.

$$LF(z) = \frac{2z^{-1} - (2 - 3a)z^{-2}}{(1 - z^{-1})^2} \quad (7)$$

$$NTF(z) = \frac{1}{1 + LF(z)} = \frac{(1 - z^{-1})^2}{(3a - 1)z^{-2} + 1} \quad (8)$$

From the Matlab modeling, the input swing of the first integrator is about 0.4V, on the other hand, the output swing of the first and the second integrator are 0.2V and 0.05V for full scale input, as shown in Fig. 4 respectively, which is reasonable for the design of the op-amp in the first integrator. Due to the feed-forward topology, the input swing of the first integrator decreases a lot, which ensures low harmonic distortions from the integrators. The signal transfer function at the input of the SC integrator (node B) can be calculated as in eq. (9), where Q_N is the quantization noise. That also con-

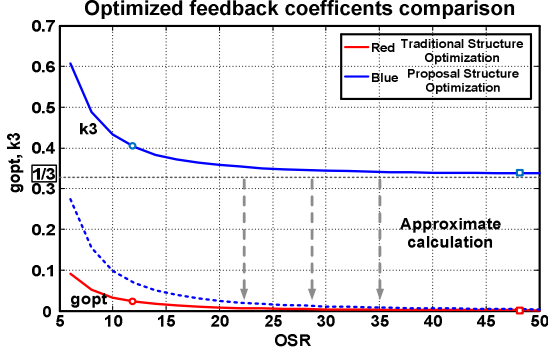

Fig. 5. Comparison of Approximate calculation in the two cases.

firmly that the main path of the structure only deals with the quantizer error signal, which can reduce the requirements of the op-amp, resulting in lower power consumption.

$$N_B(z) = -(1-z^{-1})(1-2/3z^{-1}) \cdot Q_N \quad (9)$$

In the proposed structure there is also a local feedback k_3 from the back end of the second integrator forwarded to the input of the first integrator. Thus, allowing the realization of zero optimization. As can be seen, if the coefficient k_3 is equal to $a(1+g_{opt})$, the LF and NTF now become,

$$LF_{opt}(z) = \frac{2z^{-1} - z^{-2}}{(1-z^{-1})^2 + 1/9 \cdot g'_{opt} z^{-2}} \quad (10)$$

$$NTF_{opt}(z) = \frac{1}{1+LF_{opt}(z)} = \frac{(1-z^{-1})^2 + 1/9 \cdot g'_{opt} z^{-2}}{1+1/9 \cdot g'_{opt} z^{-2}} \quad (11)$$

Compared with Eq. (1) and (2), it can be evaluated that

$$g'_{opt} = 9 \cdot g_{opt} \approx 9 \cdot \alpha_{opt}^2 \quad (12)$$

$$k_3 = 1/3 \cdot (1+9 \cdot g_{opt}) \approx 1/3 + \pi^2 / OSR^2 \quad (13)$$

The variation of the coefficient g is 9 times larger than before. In addition, the coefficient of this local feedback becomes a large value above $1/3$, which is reasonable for guaranteeing that the KT/C noise is not too large, implying easier handling in real implementation. In other words, if the OSR increases further, the rate of change for g will slowly get close to 0, while it will still be in a reasonable range when compared to the original value. The approximate calculation of the traditional and the proposed structure is depicted in Fig. 5. The dotted line is the down shift of the proposed optimization for intuition. It can be seen that the slope of k_3 over g_{opt} now is much smoother, leaving more margin for high OSR applications.

B. Circuit Implementation - Example

An example of circuit implementation of the first integrator is presented in Fig. 6. Half-cell has been drawn for simplicity. In phase \overline{CLK} , signals from output of the first and second integrators V_{OUT_1P} and V_{OUT_2N} , together with input V_{INP} and feedback D_{OUT} signal are sampled first; and then in phase CLK , all the signals are integrated together. The ratio between C_{2f} and C_{12} represents the local feedback coefficient k_3 , and the positive feedback can be realized by

feeding back the output signals of the integrator in the same phase.

IV. SIMULATION RESULTS

A system level simulation based on the proposed 2nd order $\Sigma\Delta$ modulator is verified with a 4-bit flash quantizer with ideal DAC feedback. The bandwidth of the input signal is 10MHz, and the OSR is set to be 12. The power spectral densities (PSD) of this $\Sigma\Delta$ modulator with and without zero optimization have been depicted in Fig. 7. The red curve represents the performance with no zero shifting, and the blue curve represents the power spectrum with the optimized coefficient $g_{opt}=0.21$ for the best zero location. The local feedback coefficient now becomes $k_3=a(1+g_{opt})=1/3+0.07$. The Matlab simulation result shows 5dB SNDR improvement for infinite op-amp gain, and the zero-optimized modulator can achieve 70.1dB SNDR with an input signal amplitude and frequency of -3 dBFS and 1.85MHz, respectively. It should be mentioned that shifting zeros from DC decreases the noise filtering around DC, significantly, in this 2nd order modulator, as the noise floor in low frequency range has been flattened. In both cases the coefficients in the local feedback are easily implemented by using the ratio of two capacitances. While, in the traditional structure, the ratio of capacitances is approximately equal to 0.01, any small mismatch may destroy the performance seriously. The circuit simulation results, with 60dB finite op-amp gain in the two integrators, can reach 68.7dB SNDR with an obvious zero shifting spectrum, as shown in Fig. 8.

For high OSR application, i.e. 48, the zero optimization can be realized to achieve 99.3dB SNDR with 5.2dB improvement by setting $a=1/3$ and $g_{opt}=0.02$, as shown in Fig. 9, also in the case of ideal integrators. The value of the local feedback coefficient is also reasonable. Together with the approximate calculation that has been drawn in Fig. 5, this simulation also proves that the proposed structure is very useful in high OSR. Actually, it leaves a larger margin for the variation of the local feedback to optimize the zero location than before, since the coefficient is much smaller than 0.01.

To further verify this novel loop filter with embedded NTF zero optimization, the coefficient mismatches of the two integrators in the system must be considered. Normally, a large mismatch may cause stability problems in the $\Sigma\Delta$ modu-

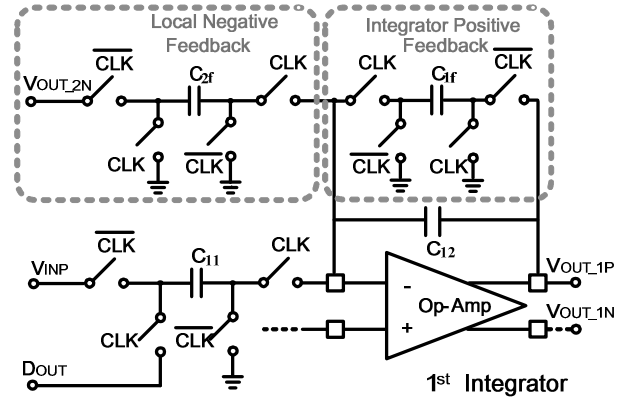

Fig. 6. Circuit implementation of the first integrator.

lator practical implementation. In this case, the mismatch E of the coefficient a in the first integrator feedback has been swept versus the performance, for the purpose of stability. As shown in Fig. 10, the error E of $\pm 20\%$ will affect the performance up and down between 65dB and 70dB, in the range of only 5dB. Although this changing interval of SNDR is very small, in reality this mismatch will not degrade the performance. The performance's summary of the proposed loop filter with relaxed intrinsic NTF zero-optimization based modulator is listed in Table 1.

TABLE I. SUMMARY OF THE MODULATOR'S PERFORMANCE

Specification	Low OSR	High OSR
Oversampling Ratio	12	48
Input Bandwidth	10MHz	10MHz
Supply Voltage	1V	1V
Peak SNDR	70.1dB	99.3dB
SNDR Improvement	5dB	5.2dB
Optimization Coefficient	0.21	0.02

V. CONCLUSIONS

A new 2nd order architecture with embedded zero optimization has been presented. Two integrators and one local feedback are used to realize the desired noise transfer function. Besides, the coefficient of the local feedback is also utilized to relax the zero optimization. By using this structure, the 2nd order modulator achieves 70.1dB/99.3dB SNDR with enhanced 5dB/5.2dB improvement, and, the value of the coefficient has been relaxed from 0.01 to 0.4 or 0.34 for zero optimization in relative low or high OSR, respectively. The proposed technique significantly suppresses the requirements in practical implementations, and should be very useful in higher order $\Sigma\Delta$ systems.

ACKNOWLEDGMENT

This work was financially supported by the Research Committee of the University of Macau and Macau Science & Technology Development Fund (FDCT).

REFERENCES

- [1] S. R. Norsworthy, R. Schreier, and G. C. Temes, et al., *Delta-Sigma Data Converters – Theory, Design, and Simulation*. Piscataway, NJ: IEEE Press, 1996.
- [2] Matt Park et al., "A 0.13 μ m CMOS 78dB SNDR 87mW 20MHz BW CT Delta-Sigma ADC with VCO-Based Integrator and Quantizer," *ISSCC Dig. Tech. Papers*, pp. 170-171, Feb. 2009.
- [3] Ranjbar, M; Oliaei, O.; "A Multibit Dual-Feedback CT $\Delta\Sigma$ Modulator With Lowpass Signal Transfer Function," *IEEE Trans. on Circuit & Systems-I: Regular Papers*, vol.58, no.9, pp.2083-2095, Sep. 2011.
- [4] Mitteregger, G. et al.; "A 2-mW 640-MHz CMOS Continuous-Time $\Sigma\Delta$ ADC With 20-MHz Signal Bandwidth, 80-dB Dynamic Range and 12-bit ENOB," *IEEE J. Solid-State Circuits*, vol.41, no.12, pp. 2641-2649, Dec. 2006.
- [5] Zambaghi, R.; Fiez, T.S.; Temes, G.; "A new zero-optimization scheme for noise-coupled $\Sigma\Delta$ ADCs," in *Proceedings IEEE ISCAS 2010*, pp.2163-2166, May 2010.
- [6] R. Schreier and G. C. Temes, *Understanding Delta-Sigma Data Converters*, Piscataway, NJ: IEEE Press 2005.

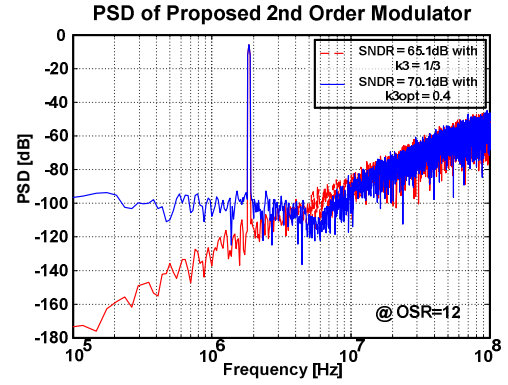

Fig. 7. Performance of the proposed structure with OSR=12.

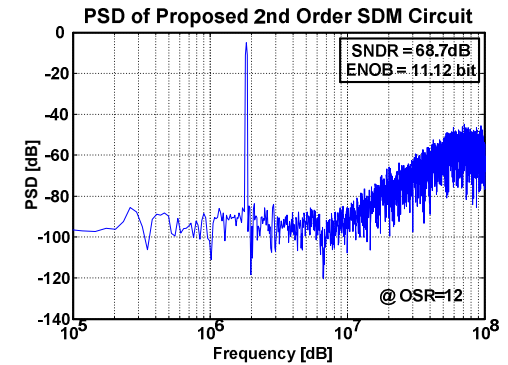

Fig. 8. Performance result of the circuit simulation with OSR=12.

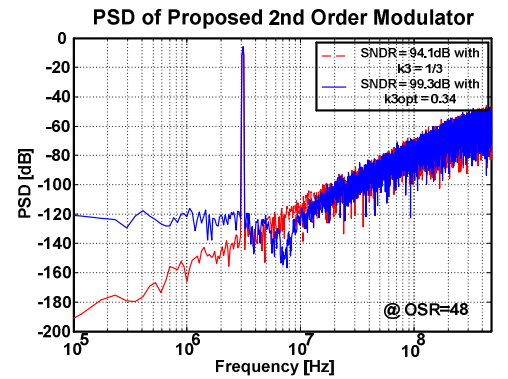

Fig. 9. Performance of the proposed structure with OSR=48.

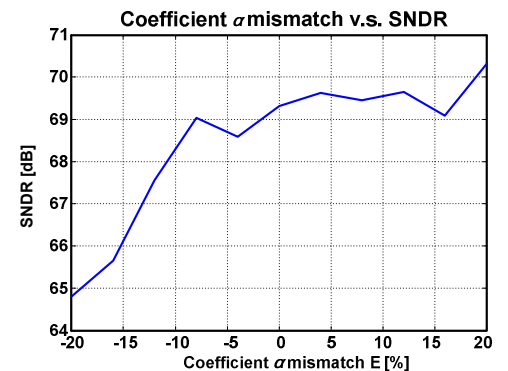

Fig. 10. Coefficient mismatch versus SNDR.